

DCM-500B_H-OS

OPTI-SERVE SERIES

SANITARY CUBELET ICE MACHINE/DISPENSER

Item # _____

Project: _____

Qty: _____

*AutoCad available on KCL

DCM-500B_H-OS

4/13

Item # 13147

DIMENSIONS

W x D x H

DCM-500B_H-OS
26 x 22^{1/2} x 40

SD-450
26^{1/4} x 22 x 32^{1/2}

SD-500
25^{9/10} x 22 x 32^{3/4}

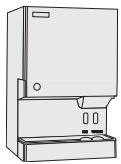

DCM-500
Countertop



DCM-500
Countertop
with optional
6" legs

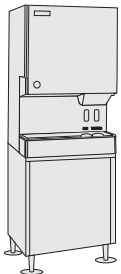

DCM-500
Floor Model
with optional
stand

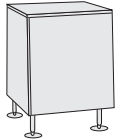

SD-450
optional
stand

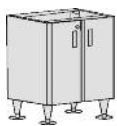

SD-500
optional
stand

DCM-500BAH-OS

Air-Cooled
Shown on an optional
SD-500 Stand



DCM-500BWH-OS

Water-Cooled



*Transparent drinkware may affect dispensing operations

DCM-500B_H-OS

- CleanCycle 12® - Every 12 hours, unit performs 15 minute purge to rid itself of impurities 
- LED Remote sensor for hands-free operation
- Sealed LED housing prevents moisture from entering, eliminating the possibility of an electrical short
- Corrosion resistant stainless steel exterior
- Up to 618 lbs. of ice production per 24 hours, with 40 lbs. built-in storage
- Easy to chew, cubelet ice
- Self contained design reducing opportunities for cross contamination
- Dispenses ice and water
- Removable air filters (Air-cooled model only)
- Protected by H-GUARD Plus Antimicrobial Agent 

SD-450 Stand / SD-500 Stand

- Heavy duty stand for floor model icemaker/dispenser
- Corrosion resistant stainless steel exterior
- Easy cleaning with attractive appearance
- Locking doors standard on SD-500

Warranty

Valid in United States, Canada, Puerto Rico, & U.S. Territories. Contact factory for warranty in other countries.

Three Year - Parts & Labor on entire machine. (Serial numbers Vxxxxxx) and after.)

Five Year - Parts on: Compressor, air-cooled condenser.



ISO9001-ISO14001



DCM-500B_H-OS SANITARY CUBELET ICE MACHINE/DISPENSER - OPTI-SERVE SERIES

DIMENSIONS
W x D x H

DCM-500B_H-OS	26" x 22 1/2" x 40"
SD-450	26 1/4" x 22" x 32 1/2"
SD-500	25 9/10" x 22" x 32 3/4"

- Hands-free ice machine/dispenser
- Optional stand
- Optional stand with locking doors

AIR-COOLED

Water Temp ° F.	50°	70°	90°
Air Temp ° F. 70°	618	590	561
Air Temp ° F. 80°	534	509	484
Air Temp ° F. 90°	461	450	418

WATER-COOLED

Water Temp ° F.	50°	70°	90°
Air Temp ° F. 70°	567	549	539
Air Temp ° F. 80°	529	519	509
Air Temp ° F. 90°	500	495	481

UTILITY CONSUMPTION

Model Number	Approximate Electrical		KWH per 100 LBS.	
	90/70	70/50	90/70	70/50
DCM-500BAH-OS	1055W	989W	5.62	4.02
DCM-500BWH-OS	930W	985W	4.8	4.0

SPECIFICATIONS

Model Number	Condenser	Amperage	Min. Circuit Ampacity	Shipping Weight
DCM-500BAH-OS	Air-Cooled	12.9	20	290 lbs.
DCM-500BWH-OS	Water-Cooled	11.5	20	290 lbs.
SD-450	N/A	N/A	N/A	110 lbs.
SD-500	N/A	N/A	N/A	98 lbs.

CUBELET DIMENSIONS

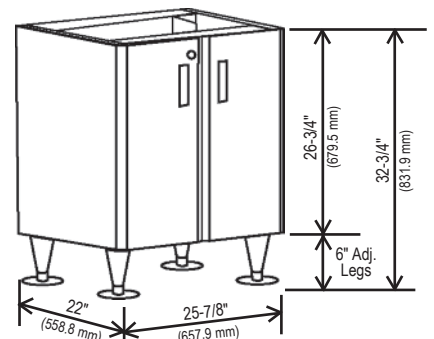
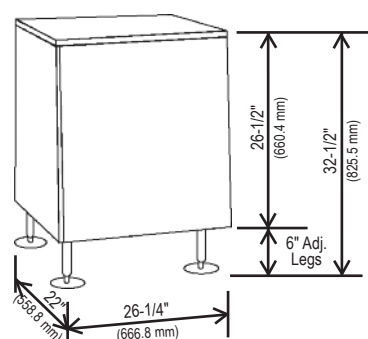
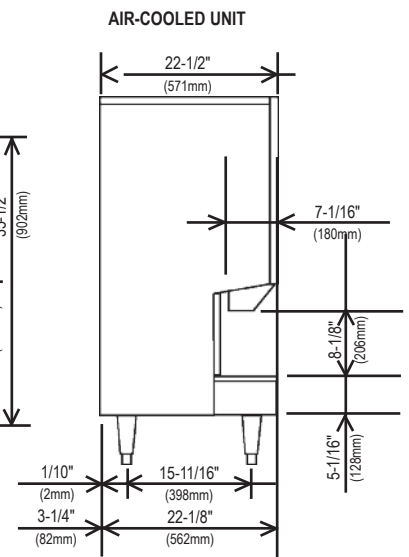
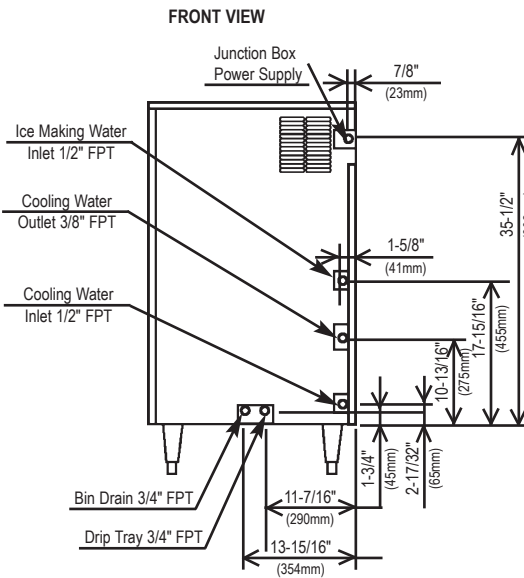
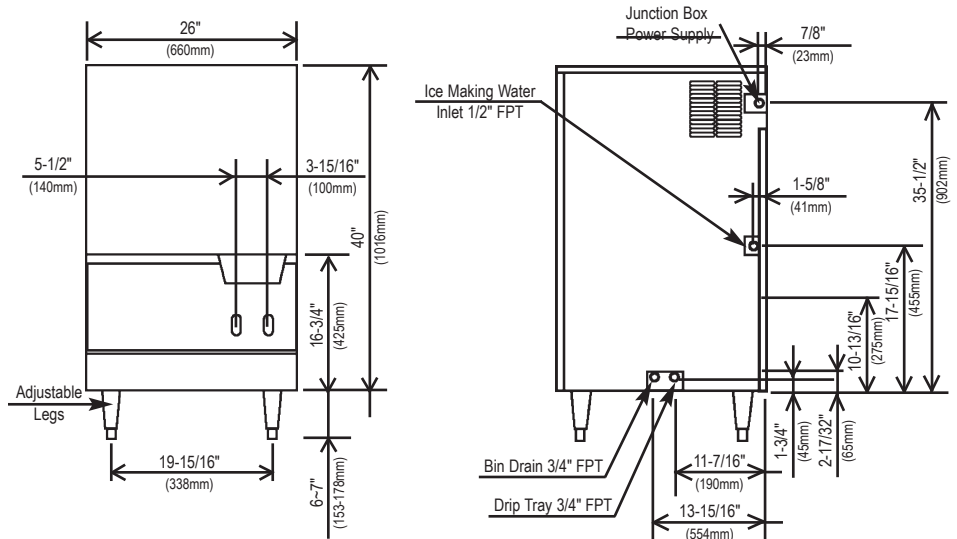
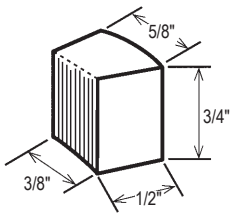

ELECTRICAL & PLUMBING/DCM-500BAH-OS

- 115V/60/1
- 20 amp Max Fuse Size
- 1/2" OD copper or equivalent independent water supply
- 3/4" independent drain connection



© HOSHIZAKI AMERICA, INC.

618 Hwy. 74 S., Peachtree City, GA 30269

OPERATING LIMITS

- Ambient Temp Range 45 - 100°F
- Water Temp Range 45 - 90°F
- Water Pressure 10 - 113psig
- Voltage Range 104 - 127V

SERVICE

- Panels easily removed and all components accessible for service.
- Removable/cleanable air filter.

TEL 1-800-438-6087

FAX 1-800-345-1325

www.hoshizaki.com

Printed in U.S.A.

